



# Fine Fabricators



[www.finefabricators.com](http://www.finefabricators.com)

**RELIABLE  
NAME  
IN  
POULTRY  
INDUSTRY**

- ◆ Fine Classic Nest
- ◆ Fine Roll Out Egg Nest
- ◆ Broiler Feeding & Drinking System
- ◆ Ventilation Equipment
- ◆ Light Control Baffle
- ◆ Semi Auto Processing Unit



*Meat Shop Company Presentation*

# Table of content

1. General information,
2. Way Forward,
3. Shop Renderings,
4. Equipment Features,
5. Semi Auto Processing Lines,
6. Projects & references,
7. Why Fine Fabricators???,

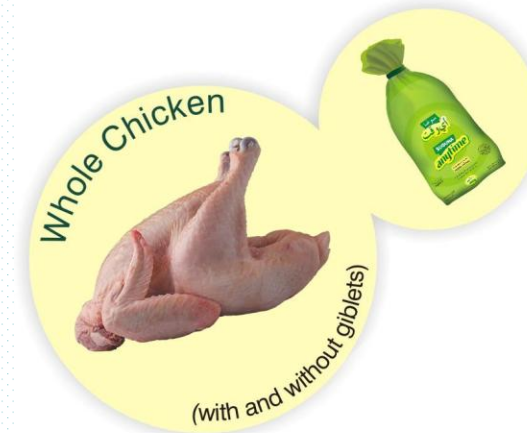

# 1. General information

- Allows dressing of birds in a hygienic manner
- Insulated enclosed Scalding Tank with gas fitting arrangement and temperature gauge
- Slaughtering Cones with blood catch tray and plastic tub to collect blood
- De-feathering Machine 5 Birds / Batch (Avg Wt 1.8 kgs/bird)
- Evisceration Table and Double Sinks included
- Portioning Machine to cut precise portions of the processed bird



## 2. Way Forward

**PreSales/  
Marketing  
Services**

**Pre Project  
Consultancy**

**Implementation Phase**

**After Sales  
Support**

- Market Research
- Acquisitions Assistance
- Technical Knowledge
- Architectural Planning
- ROI Planning

- Procurement
- Installation
- Factory Building
- Engineering Support

- AMC
- QC
- Analysis
- Helpline
- Spares



### 3. Shop Renderings



### 3. Shop Renderings





### 3. Shop Renderings



# Standard Shop Layout

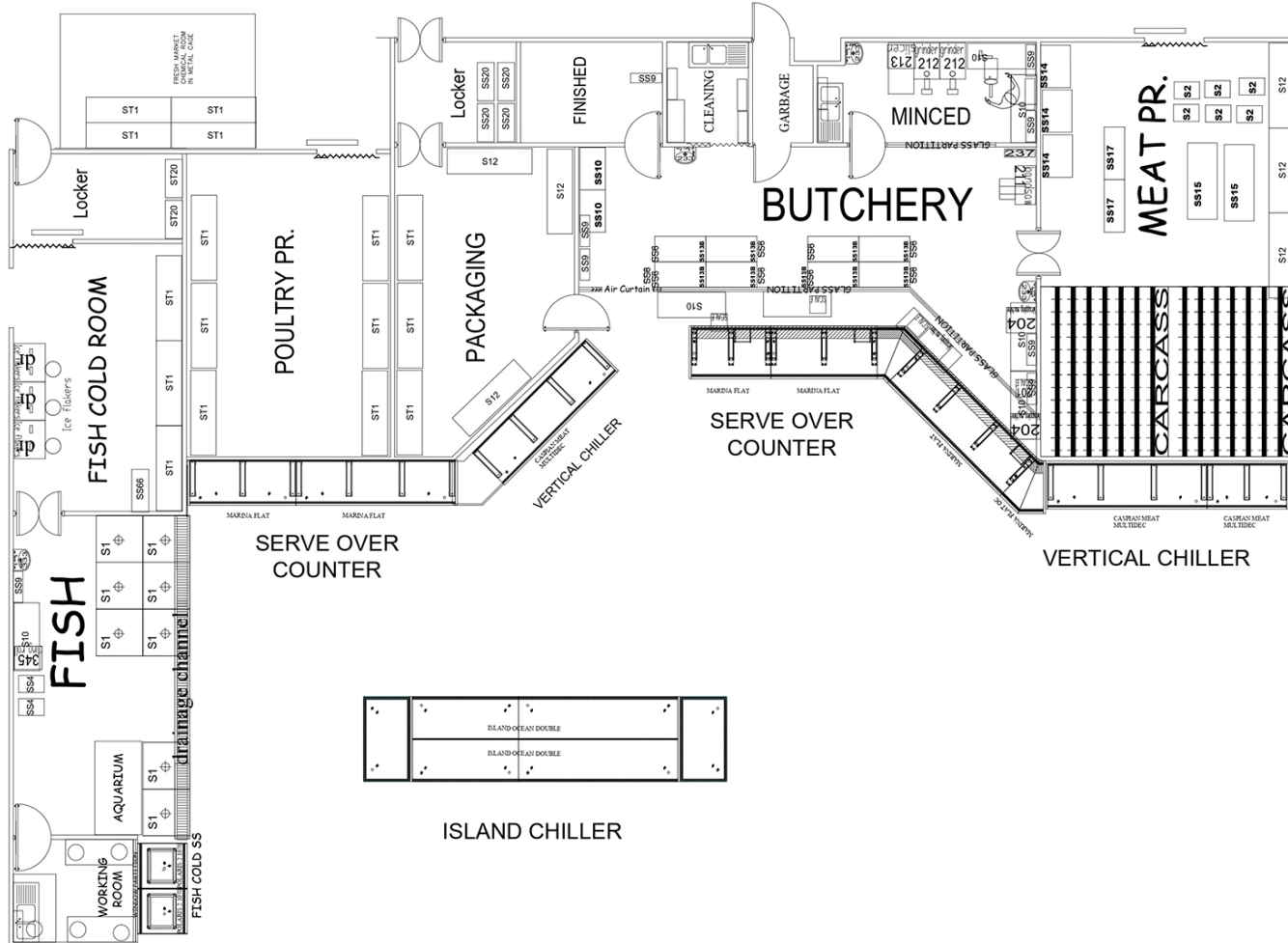



# Standard Shop Layout

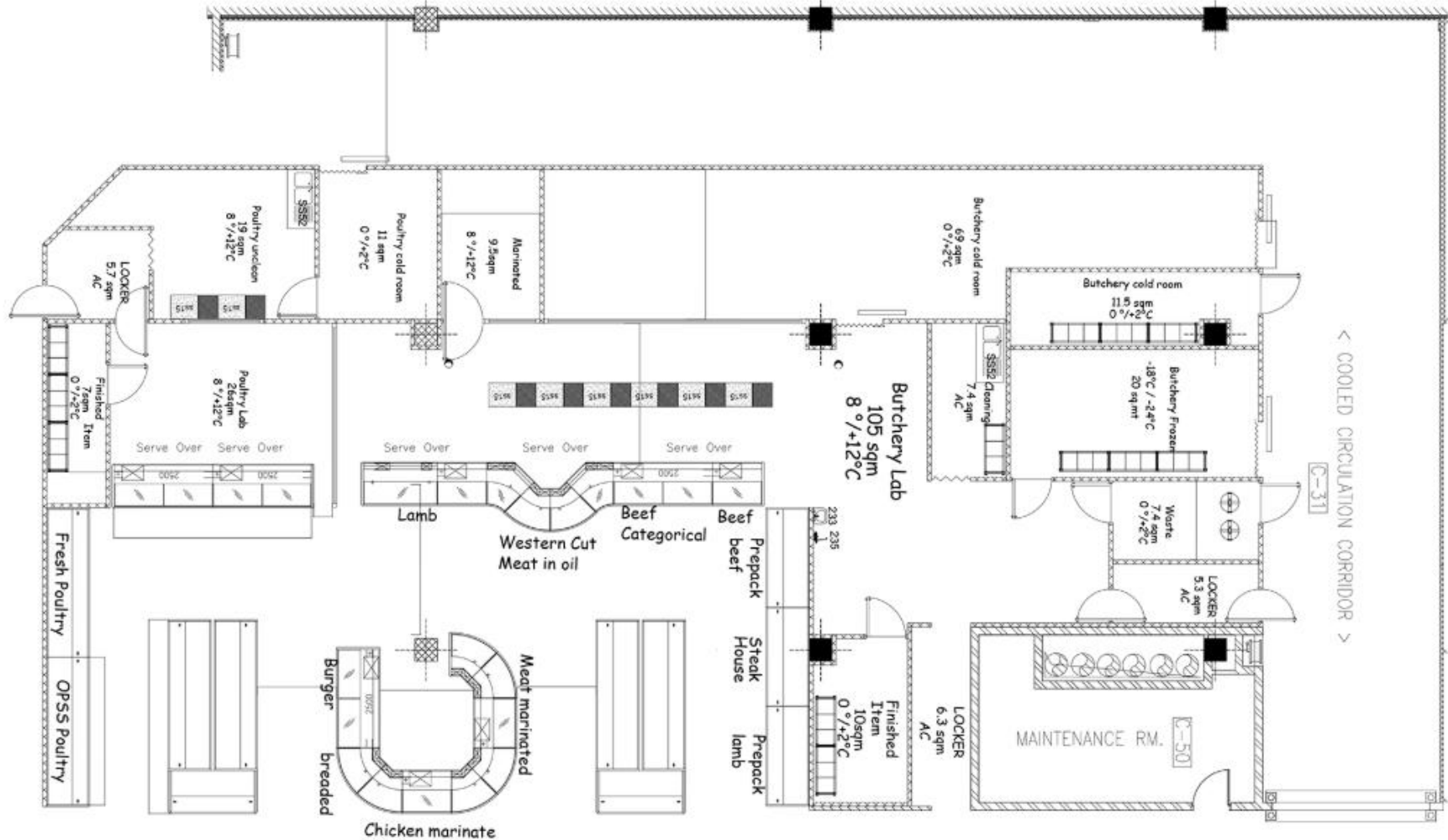

# Standard Shop Layout

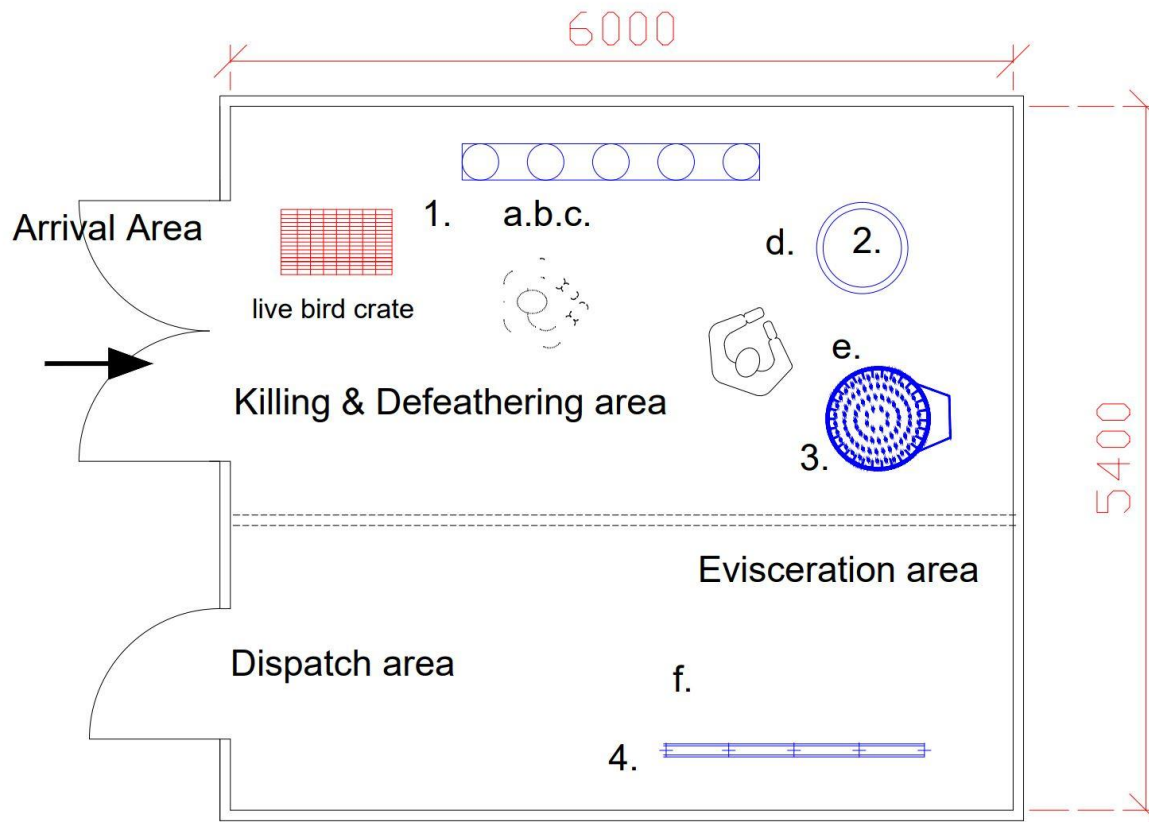

- |                           |                                |
|---------------------------|--------------------------------|
| 1. Killing Cones (5 x)    | a. Hanging                     |
| 2. Scalding Tank BK-1     | b. Killing                     |
| 3. Plucking machine TRM-1 | c. Debleeding                  |
| 4. Bar with EV shackles   | d. Into Scalding Tank          |
|                           | e. Into Plucking machine       |
|                           | f. Evisceration at EV-shackles |

# *Standard Shop Layout*





# *Standard Shop Layout*



# *Standard Shop Layout*



# *Standard Shop Layout*





**FREE**  
Home Delivery  
051 - 5194600  
051 - 5194602

**Chicken**  
Unchained  
A Free Range Chicken

**GO Fresh**  
Meat Shop



CHICKEN MUTTON VEAL FISH  
FREE Home Delivery 051-5194600  
051-5194602

Now Open

CHICKEN MUTTON  
FISH VEAL  
We ENSURE You Eat PURE

GO Fresh  
Meat Shop  
VEAL  
MUTTON  
FISH  
CHICKEN  
We ENSURE You Eat PURE



We ENSURE You Eat PURE

# 4. Equipment Features 1000BPD-1500BPD

## Specifications

### CP 1000 GB

- Bird Loading Table
- 12 Killing Cones
- 24" Scalding Tank
- Strong arm unit (10 Birds/Batch)
- CP1000GB (De-feathering Machine)
- 6'x4'x3' Evisceration Table
- Kleen Kut-K2
- Bagging Cone
- Spares tool kit

### CP 1500 GB

- Bird Loading Table
- 24 Killing Cones
- 30" Scalding Tank
- Strong arm unit (15 Birds/Batch)
- CP1500GB (De-feathering Machine)
- 6'x4'x3' Evisceration table
- Kleen Kut-K3
- Bagging Cone
- Spares tool kit

### CP 1000 & 1500 GB Components

Strong Arm with Scalding Tank and De-feathering Unit

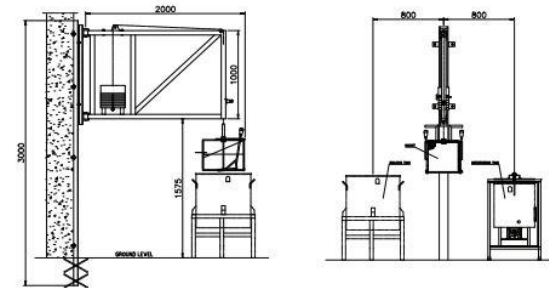

12 Killing Cones

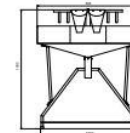
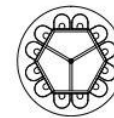

24 Killing Cones

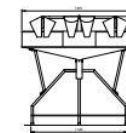

Evisceration Table

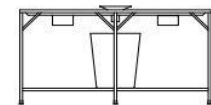
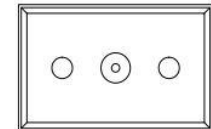

## 4. Equipment Features Plucking Machine

### Specifications

- 100% SS 304 construction
- Available with or without door
- With Gear Box/ Chain Drive/  
Belt Drive
- Drum with rotating disc
- Water inlet pipe
- CE mark motors

*CP500 integrates with Hycab Unit (Cabinet Plant)*

*CP1000 integrates with Manual Semi-Automatic Plant (Strong Arm CP1000GB)*

*CP1500 integrates with Manual Semi-Automatic Plant (Strong Arm CP1500GB)*

*CP2500 integrates with Overhead Conveyor Plant*

CP 500 DX- Footprint

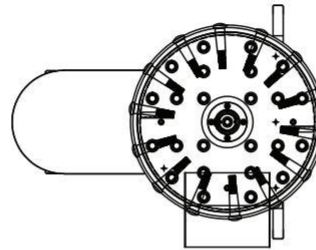

CP 1000 GB- Footprint

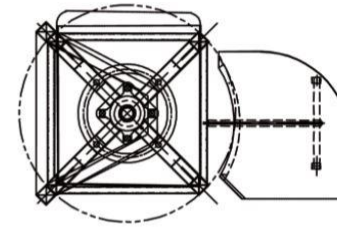

CP 1500 GB- Footprint

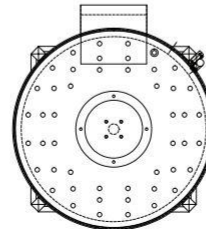

CP 2500 GB- Footprint

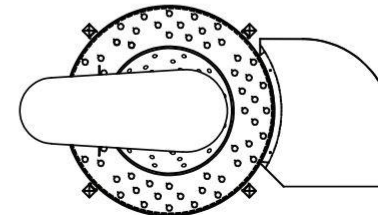



## 4. Equipment Features Portion Cutter

### Specifications

- 100% SS 304 construction
- Rotating High-speed Blade
- Poly V Belt Drive
- Specially designed guide bar and spindle

*All three variants of the Kleen Kut integrate with Portioning Machine Table, De-feathering Machine, Hy-Cab Unit, Strong Arm Unit and the Overhead Conveyor Plant*

Portioning Machine K1 - Side View

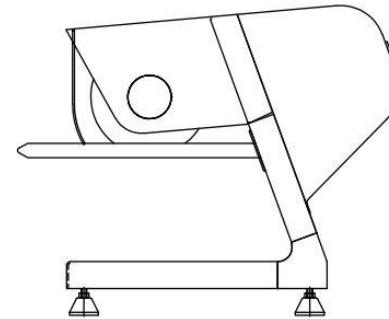

Portioning Machine K2- Front View

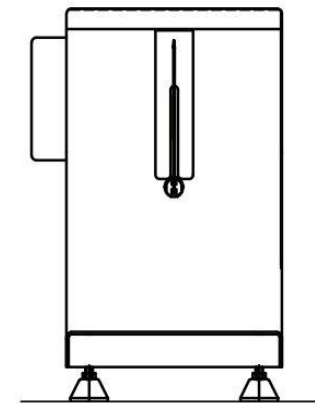

## 5. Semi Auto Processing Lines



# 5. Semi Auto Processing Lines

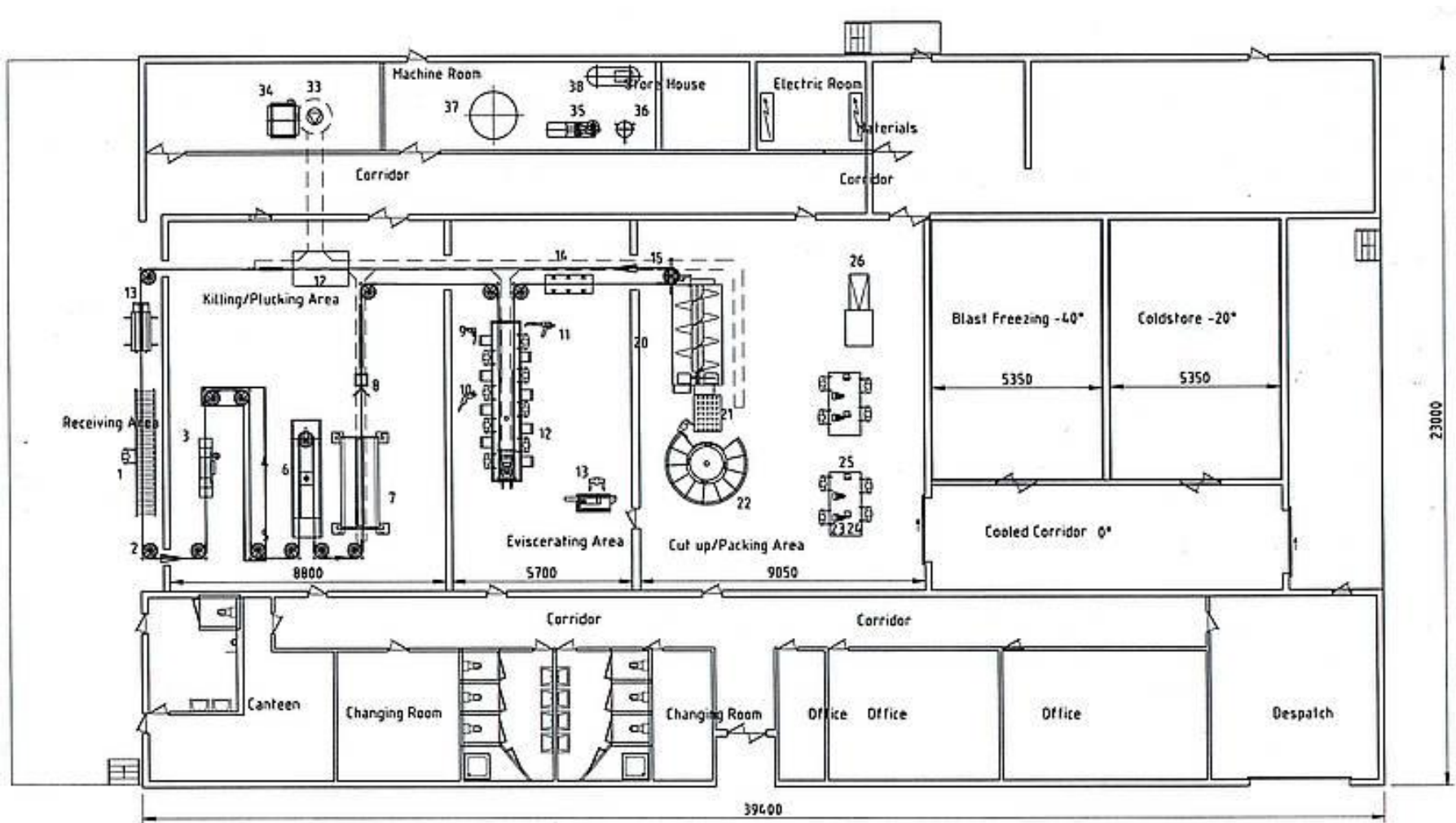



## 5. Semi Auto Processing Lines





## 6. Few Projects & references –Meat Shops



Lahore



Islamabad

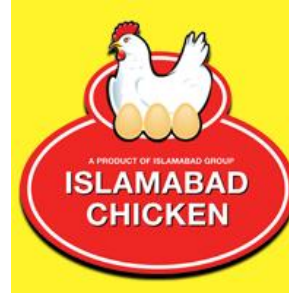

Islamabad



Mansehra



Multan



Lahore



Sadiqabad



Meat



Islamabad



Healthy & Hygienic Meat

Sahiwal



Karachi



Karachi

## 7. Why Fine Fabroicators?

- *high quality,*
- *flexibility,*
- *competitve pricing,*
- *good manufacturing time,*
- *technical support,*
- *products comply with different standards (German, UK, USA),*
- *opened for custom fabrications,*
- *transparent rules & fair cooperation,*
- *aware of HACCP product features,*
- *experience in cooperation with international key accounts,*



[www.finefabricators.com](http://www.finefabricators.com)

## For Further Details Contact

Muhammad Akmal

Director Commercial

0092-300-8567234 

0092-322-4317370 

[finefabricators247@gmail.com](mailto:finefabricators247@gmail.com)

[akmalglobal@yahoo.com](mailto:akmalglobal@yahoo.com)

[www.finefabricators.com](http://www.finefabricators.com)

Taij Garh Road, Grand Trunk Rd, opposite Alghani Garden,  
phase 3 Manawan, Lahore